

Limit-value switch for frequency, input automotive alternator



RFW5..

Limit-value switches

- Straightforward application
- Suitable for severe operating conditions
- Compact construction
- No additional operating voltage required
- Switching point freely adjustable by drum scale
- Anti-tamper seal for drum scale
- Provision made for fine adjustment of measuring range
- Meet high EMC-requirements
- **CE** requirements
- Volt-free output as normally closed contact or normally open contact
- Open-circuit or closed-circuit variants available
- Open-circuit devices with integrated push button to simulate an increased sensor signal for test functions without critical machine loading
- Operating characteristics displayed by integrated LEDs
- Flame-inhibiting and self-extinguishing body

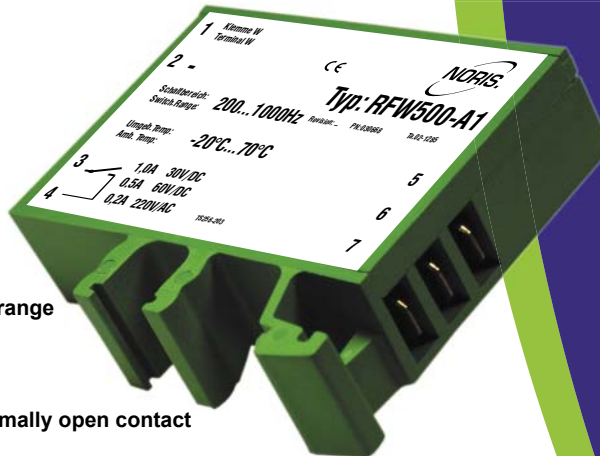

Image RFW500-A1



Limit-value switches of series 5

Limit value switches of the series 5 are designed to monitor and process electric measured variables.

Working principle: When the actual value of the measuring signal supplied reaches the setpoint, the built-in relay will operate. The switching status of the relay contact may, for instance, be monitored or individually processed by a machine controller.

General notes on Type RFW5..

Description RFW5..

The Type RFW5.. is designed for monitoring a frequency signal of an automotive alternator. The terminal W supplies a pulsating DC-voltage from a coil winding of the alternator with subsequent rectification. There is no signal at standstill. Above a predetermined speed level, a voltage is generated and available as a pulsating DC-voltage of approx. 26 V/DC. Evaluation of this voltage is frequency-oriented. The voltage at the same time provides the operating voltage for the limit-value switch. The frequency range is obtained automatically and there is no need for calibration. The minimum range is the no-load speed of the alternator of approx. 1,500 rpm at approx. 150 Hz. The maximum range is dictated by the maximum speed of the prime mover of approx. 12,000 rpm at approx. 1,200 Hz. Access is provided to a trimming potentiometer for subsequent adjustments of the measuring range. Settings of the switching point are made at the short top side of the device by means of a drum scale graduated in per cent. The maximum speed of the prime mover defines 100%. Settings can be at any value between 20 - 100%. In selecting the limit value it is important to take into consideration any step-up/step-down

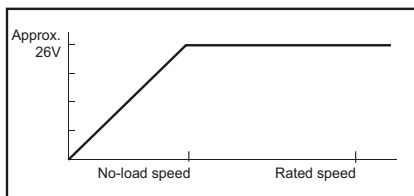

ratios between the prime mover and the alternator. No switching functions are provided below the no-load speed..

Integrated test button for test purposes

Open-circuit devices have a test button integrated for testing purposes. As long as this button is kept pressed, the preselected limit value is decreased by abt. 15%. This enables safety functions, such as an overspeed trip to be tested without it being necessary to run the machine in the critical range.

Volt-free relay contact, closed-circuit or open-circuit version

A volt-free relay contact is provided as a normally closed or normally open contact for outputting and further processing. In addition, there is a choice between closed-circuit and open-circuit devices.

In the case of closed-circuit devices, the output relay is pulled up in the normal state of operation with the operating voltage applied. It drops off upon the limit-value being exceeded or if the operating voltage fails.

In the open-circuit variant, the output relay pulls up when the limit-value is exceeded with the operating voltage applied. Failure of the voltage will not result in any switching function below the switching point.

Technical Data

Series RFW5..	
Operating voltage	U _o supply from terminal W
Ripple	-
Reverse voltage protection	Integrated
Overvoltage	2.5 times U _r up to 2 ms
Voltage drops	-
Power consumption	Approx. 70 mA (24 V/DC)
Galvanic isolation	Between input signal and operating voltage
Input signal	Terminal W of a 24 V automotive alternator
Input overloading	< U _r
Output contact	Volt-free NOC or NCC, closed circuit or open circuit
Maximal switching capacity	30 W (1 A at 30 V/DC; 0.5 A at 60 V/DC) 40 W (0.2 A at 220 V/AC)
Switching point	Adjustable on tamper-proof drum scale between 20 ... 100%
Reproducibility	< +/- 0.2%
Linearity of scale	< +/- 1.5%
Hysteresis	Approx. 1.5%
Test button function	Switching point lowered by approx. 15% (only open-circuit devices)
Error class	IEC51-1 1.5%
Temperature sensitivity	< +/- 0.1% je 10 °K
Voltage sensitivity	< +/- 0.1% for 10% change in operating voltage
Reaction time	f=50 Hz / 0,25 s, f=100 Hz / 0,2 s, f=1 kHz / 0,1 s, f=10 kHz / 50 ms
Vibration resistance	IEC60068-T2-6 15g increased strain, characteristic 2 (10 ... 100 Hz)
Shock resistance (impact)	DIN IEC60068-T2-27 300 m/s ² with 18 ms dwell time
Climatic test	IEC60068-T2-30
Operating temperature	-20 °C ... +70 °C
Shelf temperature	-45 °C ... +85 °C
Humidity	RH 96% maximum
ESD	IEC61000-4-2 +/- 8 kV
Electromagnetic field	IEC61000-4-3 10 V/m f=10 kHz ... 2000 MHz, 80% AM @ 1 kHz 10 V/m f=900 +/- 5 MHz, 50% AM @ 200 Hz 10 V/m f=1800 MHz +/- 5 MHz, 50% AM @ 200 Hz
Burst	IEC61000-4-4 +/- 2 kV supply +/- 1 kV sensor
Surge	IEC61000-4-5 sym. +/- 1 kV (R _i =2 Ω) asym. +/- 2 kV (R _i =2 Ω)
HF-susceptibility	IEC61000-4-6 3 V _{pp} 80% AM @ 1 kHz f=0.01 ... 100 MHz
LF-susceptibility	IEC60553 3 V _{pp} 0.05 ... 10 kHz
Interference field intensity	Basis CISPR 16-1, 16-2 reduced characteristic
Connection	DIN46244 flat connector, gold-plated A6.3 x 0.8
Protection class	DIN EN60529 Body IP20, terminals IP00
Mounting	Snap-fit on top-hat channel or G-channel
Installed position	Any
Body material	Thermoplastic polyester, green, fire protection class V0
Weight	55 g
Standard supply	CE requirements complied with, DIN EN 61000-6-2, DIN EN 61000-6-4, DIN EN 50155, approved by GL, LR, ABS, DNV, BV

Type key / variants

Series RFW5..	00	01
NCC in closed circuit	RFW500-R1	RFW501-R1
NOC in closed circuit	RFW500-R2	RFW501-R2
NCC in open circuit	RFW500-A1	RFW501-A1
NOC in open circuit	RFW500-A2	RFW501-A2

Device codes

R	Limit-value switch
Input signal	
FW	Frequency input for a terminal W of a 24 V automotive alternator
Type series	
5	Type 5
Input range	
00	0 ... 100 Hz
01	0 ... 1,200 Hz
Variants	
R1	Output contact as NCC in closed circuit
R2	Output contact as NOC in closed circuit
A1	Output contact as NCC in open circuit
A2	Output contact as NOC in open circuit

R FW 5 01 -A2 (RFW501-A2)

Other Data

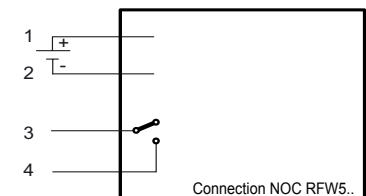
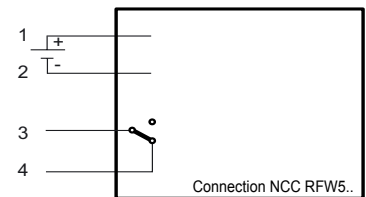
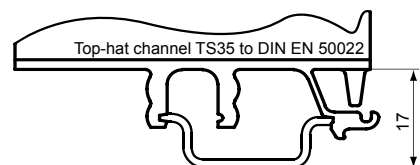
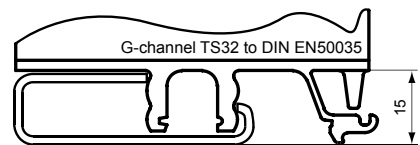
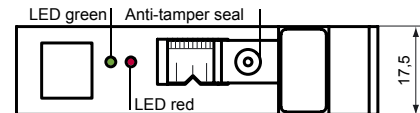
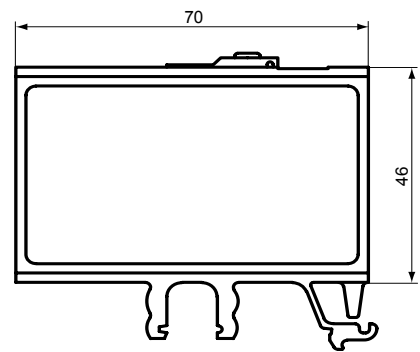

Relais position and LED code

	3/4 RFW5..-A1	3/4 RFW5..-A2	3/4 RFW5..-R1	3/4 RFW5..-R2	LED grün	LED rot
f < switch point	x	-	-	x	x	-
f > switch point	-	x	x	-	x	x

x = contact closed / LED lighting
 - = Kontakt open / LED out
 o = LED flashing



NORIS Automation GmbH
 Muggenhofer Strasse 95

D - 90429 Nürnberg
 Germany
 Tel.: +49 (0)9 11/32 01-0
 Fax: +49 (0)9 11/32 01-150
 info@noris-automation.com
 www.noris-automation.com