

Limit-value switch for frequency, input sinusoidal signal



RFJ5../RFS5../RFG5..

Limit-value switches

- Straightforward application
- Suitable for severe operating conditions
- Compact construction
- Switching point freely adjustable by drum scale
- Anti-tamper seal for drum scale
- Frequency ranges to suit customer requirements
- Provision made for fine adjustment of measuring range
- Meet high EMC-requirements
- **CE** requirements
- Volt-free output as normally closed contact or normally open contact
- Open-circuit or closed-circuit variants available
- Open-circuit devices with integrated push button to simulate an increased sensor signal for test functions without critical machine loading
- Operating characteristics displayed by integrated LEDs
- Flame-inhibiting and self-extinguishing body
- Suitable tachogenerators are available (NORIS devices GE..)

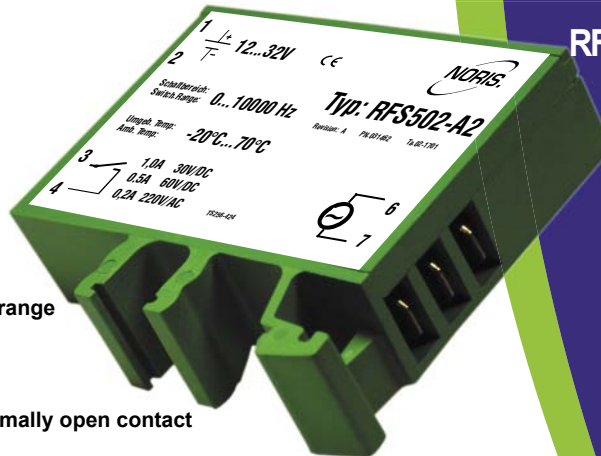

Image RFS502-A2



Germanischer Lloyd

Limit-value switches of series 5

Limit value switches of the series 5 are designed to monitor and process electric measured variables.

Working principle: When the actual value of the measuring signal supplied reaches the setpoint, the built-in relay will operate. The switching status of the relay contact may, for instance, be monitored or individually processed by a machine controller.

General notes on Type RFJ5../RFS5../RFG5..

Description RFJ5.., RFS5.. und RFG5..

- Designed to monitor a sinusoidal frequency signal
- Suitable to evaluate outputs of speed pickups; AC-tachogenerators with various signal amplitudes
- Suitable to evaluate outputs of NORIS tachogenerators, GE...-series
- Factory-set maximum range frequency adjustment between 50 Hz and 10 kHz (maximum range frequency is 100 % of drum scale)
- Trimming potentiometer for re-adjustment of measuring range
- Switching point setpoint adjustable by means of drum scale from 5 ... 100 %
- Lowest switching point: 50 Hz (RFx500..), 100 Hz (RFx501..), 1,000 Hz (RFx502..)

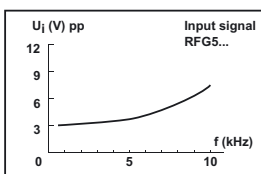
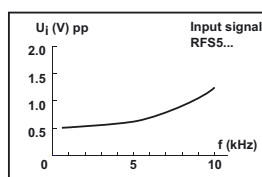
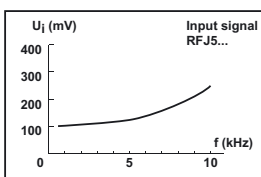

Integrated test button for test purposes

Open-circuit devices have a test button integrated for testing purposes. As long as this button is kept pressed, the preselected limit value is decreased by abt. 15%. This enables safety functions, such as an overspeed trip to be tested without it being necessary to run the machine in the critical range.

Volt-free relay contact, closed-circuit or open-circuit version

A volt-free relay contact is provided as a normally closed or normally open contact for outputting and further processing. In addition, there is a choice between closed-circuit and open-circuit devices.

In the case of closed-circuit devices, the output relay is pulled up in the normal state of operation with the operating voltage applied. It drops off upon the limit-value being exceeded or if the operating voltage fails.

In the open-circuit variant, the output relay pulls up when the limit-value is exceeded with the operating voltage applied. Failure of the voltage will not result in any switching function below the switching point.

Technical Data

Series RFJ5..., RFS5..., RFG5...	
Operating voltage	$U_o=12 \dots 32$ V/DC, $U_R=24$ V/DC
Ripple	$< 20\%$ U_o
Reverse voltage protection	Integrated
Overvoltage	2.5 times U_R up to 2 ms
Voltage drops	100% up to 10 ms
Power consumption	Approx. 50 mA (24 V/DC)
Galvanic isolation	Between input signal and operating voltage
Input signal	Sinusoidal signal, NORIS tachogenerator GE
Input overloading	RFJ5.. up to 30 V, RFS5.. and RFG5.. up to 90 V
Input resistance	RFJ5.. approx. 10 k Ω , RFS5.. approx. 30 k Ω , RFG5.. approx. 15 k Ω
Output contact	Volt-free NOC or NCC, closed circuit or open circuit
Maximal switching capacity	30 W (1 A at 30 V/DC; 0.5 A at 60 V/DC) 40 W (0.2 A at 220 V/AC)
Switching point	Adjustable on tamper-proof drum scale between 5 ... 100%
Reproducibility	$< \pm 0.2\%$
Linearity of scale	$< \pm 1.5\%$
Hysteresis	Approx. 1.5%
Test button function	Switching point lowered by approx. 15% (only open-circuit devices)
Error class	IEC51-1 1.5%
Temperature sensitivity	$< \pm 0.1\%$ je 10 °K
Voltage sensitivity	$< \pm 0.1\%$ for 10% change in operating voltage
Reaction time	$f=50$ Hz / 0,25 s, $f=100$ Hz / 0,2 s, $f=1$ kHz / 0,1 s, $f=10$ kHz / 50 ms
Vibration resistance	IEC60068-T2-6 15g increased strain, characteristic 2 (10 ... 100 Hz)
Shock resistance (impact)	DIN IEC60068-T2-27 300 m/s ² with 18 ms dwell time
Climatic test	IEC60068-T2-30
Operating temperature	-20 °C ... +70 °C
Shelf temperature	-45 °C ... +85 °C
Humidity	RH 96% maximum
ESD	IEC61000-4-2 ± 8 kV
Electromagnetic field	IEC61000-4-3 10 V/m $f=10$ kHz ... 2000 MHz, 80% AM @ 1 kHz 10 V/m $f=900 \pm 5$ MHz, 50% AM @ 200 Hz 10 V/m $f=1800$ MHz ± 5 MHz, 50% AM @ 200 Hz
Burst	IEC61000-4-4 ± 2 kV supply ± 1 kV sensor
Surge	IEC61000-4-5 sym. ± 1 kV ($R_f=2 \Omega$) asym. ± 2 kV ($R_f=2 \Omega$)
HF-susceptibility	IEC61000-4-6 3 V _{pp} , 80% AM @ 1 kHz $f=0.01 \dots 100$ MHz
LF-susceptibility	IEC60553 3 V _{pp} , 0.05 ... 10 kHz
Interference field intensity	Basis CISPR 16-1, 16-2 reduced characteristic
Connection	DIN46244 flat connector, gold-plated A6.3 x 0.8
Protection class	DIN EN60529 Body IP20, terminals IP00
Mounting	Snap-fit on top-hat channel or G-channel
Installed position	Any
Body material	Thermoplastic polyester, green, fire protection class V0
Weight	55 g
Standard supply	CE requirements complied with, DIN EN 61000-6-2, DIN EN 61000-6-4, DIN EN 50155, approved by GL, LR, ABS, DNV, BV

Type key / variants

Frequency versions:	00	01	02
NCC in closed circuit	RFx500-R1	RFx501-R1	RFx502-R1
NOC in closed circuit	RFx500-R2	RFx501-R2	RFx502-R2
NCC in open circuit	RFx500-A1	RFx501-A1	RFx502-A1
NOC in open circuit	RFx500-A2	RFx501-A2	RFx502-A2

x to be replaced with range J, S oder G of input signal
Please state upper range frequency in case of order

Device codes

R	Limit-value switch
Input signal	
FJ	Frequency input for sinusoidal signal 100mV _{pp} ... 10V _{pp}
FS	Frequency input for sinusoidal signal 500mV _{pp} ... 30V _{pp}
FG	Frequency input for sinusoidal signal 6V _{pp} ... 200V _{pp}
Type series	
5	Type 5
Input range f_B / upper-range frequency f_E / switching point f_S	
00	$f_B: 10 \dots 100$ Hz, $f_E: 50 \dots 100$ Hz, $f_S: 50 \dots 100$ Hz ($f_S \leq f_E$)
01	$f_B: 20 \dots 1,000$ Hz, $f_E: 100 \dots 1,000$ Hz, $f_S: 100 \dots 1,000$ Hz ($f_S \leq f_E$)
02	$f_B: 200 \dots 10,000$ Hz, $f_E: 1,000 \dots 10,000$ Hz, $f_S: 1,000 \dots 10,000$ Hz ($f_S \leq f_E$)
Variants	
R1	Output contact as NCC in closed circuit
R2	Output contact as NOC in closed circuit
A1	Output contact as NCC in open circuit
A2	Output contact as NOC in open circuit

R FJ 5 01 -A2 (RFJ501-A2)

Other Data

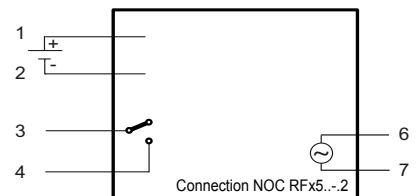
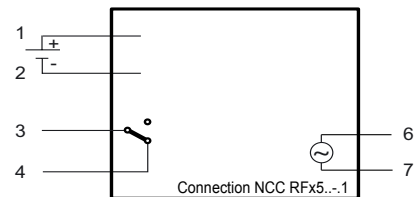
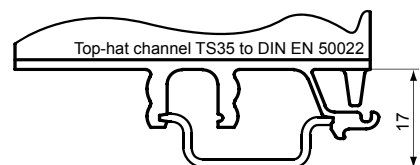
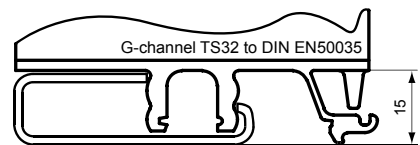
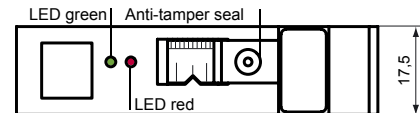
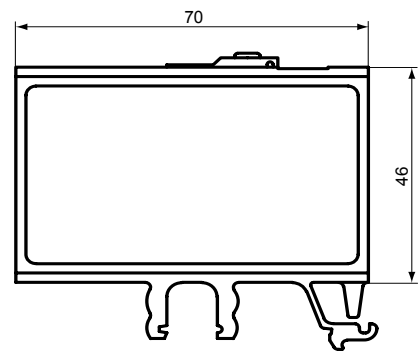

Relais position and LED code

	3/4 RFx5...A1	3/4 RFx5...A2	3/4 RFx5...R1	3/4 RFx5...R2	LED grün	LED rot
f < switch point	x	-	-	x	x	-
f > switch point	-	x	x	-	x	x

x = contact closed / LED lighting
- = contact open / LED out
o = LED flashing



NORIS Automation GmbH
Muggenhofer Strasse 95

D - 90429 Nürnberg
Germany
Tel.: +49 (0)9 11/32 01-0
Fax: +49 (0)9 11/32 01-150
info@noris-automation.com
www.noris-automation.com