

# Limit-value switch, input AC-voltage

- Straightforward application
- Suitable for severe operating conditions
- Compact construction
- Switching point freely adjustable by drum scale
- Anti-tamper seal for drum scale
- Meet high EMC-requirements  
CE requirements
- Volt-free output as make-and-break contact or make-contact
- Open-circuit or closed-circuit variants available
- Test function to simulate an increased sensor signal without critical machine loading (RW5...-S)
- Self-holding function of output relay (RW5...-S)
- Operating characteristics displayed by integrated LEDs
- Flame-inhibiting and self-extinguishing body
- Suitable sensors are available (NORIS GE.. devices)

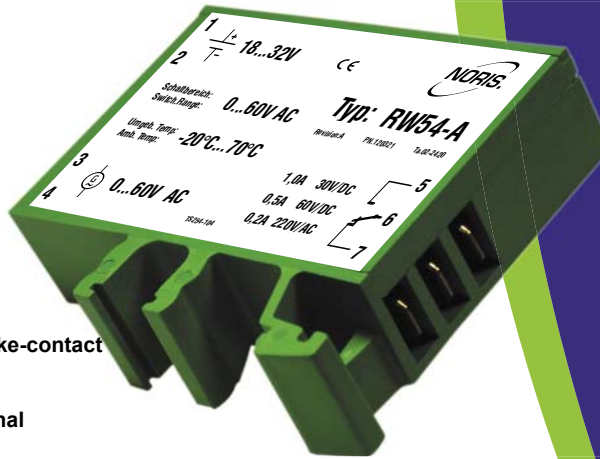
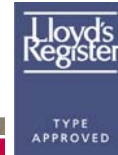

Image  
RW54-A



Germanischer Lloyd

## Limit-value switches of series 5

Limit value switches of the series 5 are designed to monitor and process electric measured variables.

Working principle: When the actual value of the measuring signal supplied reaches the setpoint, the built-in relay will operate. The switching status of the relay contact may, for instance, be monitored or individually processed by a machine controller.

## General notes on Type RW5..

### Description RW5..

- Designed to monitor an alternating voltage
- Various devices available for optimal matching to input signal
- Switching point settings possible over complete input range by means of drum scale

### Volt-free relay contact, closed-circuit or open-circuit version

A volt-free relay contact is provided as a make-and-break contact for outputting and further processing. In addition, there is a choice between closed-circuit and open-circuit devices.

In the case of closed-circuit devices, the output relay is pulled up in the normal state of operation with the operating voltage applied. It drops off upon the limit-value being exceeded or if the operating voltage fails.

In the open-circuit variant, the output relay pulls up when the limit-value is exceeded with the operating voltage applied. Failure of the voltage will not result in any switching function below the switching point.

### Testing and self-holding function of RW5...-S and RW5...-A2

The Types RW5...-S have the integrated special functions testing and self-holding. The Types RW5...-A2 have only the special function testing.

The testing function offers while the contacts 2 and 5 are connected, the limit-value signal selected on the drum scale is lowered by about 15%. In a speed monitoring application, this means that an overspeed condition can be simulated within the normal range without it being necessary to run the machine in the critical range.

The self-holding function of the RW5...-S devices hold the output relay to be kept latched after the switching operation until the relay is unlatched. The unlatching function is activated when the operating voltage as been interrupted for at least 500 ms. After activation of the unlatching function, the limit-value switch will return to its normal operating condition and will be fully operational after approximately 3 seconds

## Technical Data

Series RW5..., RW5...-S	
Operating voltage	$U_o=12 \dots 32$ V/DC, $U_R=24$ V/DC
Ripple	< 20% $U_o$
Reverse voltage protection	Integrated
Overvoltage	2.5 times $U_o$ up to 2 ms
Voltage drops	100% up to 10 ms
Power consumption	Approx. 50 mA (24 V/DC)
Galvanic isolation	Between input signal and operating voltage
Input signal	AC-voltage, NORIS tacho-generator GE
Input overloading	< 1.5 times maximal input
Input resistance	RW53.. approx.30 k $\Omega$ , RW54.. approx.60 k $\Omega$ , RW55.. approx.90 k $\Omega$
Output contact	Volt-free make-and-break contact, closed circuit or open circuit (RW5..) Volt-free NOC, closed circuit or open circuit (RW5...A2, RW5...S)
Maximal switching capacity	30 W (1 A at 30 V/DC; 0.5 A at 60 V/DC) 40 W (0.2 A at 220 V/AC)
Switching point	Adjustable on tamper-proof drum scale between 2 ... 20 V/AC for RW53..., 6 ... 60 V/AC for RW54..., 9 ... 90 V/AC for RW55..
Reproducibility	< +/- 0.2%
Linearity of scale	< +/- 1.5%
Hysteresis	Approx. 1.5%
Test function	Connect 2/5 to lower switching point approx. 15% (only RW5...S/RW5...A2)
Self-holding function	Relais is held till operating voltage is interrupted min. 500 ms (RW5...S)
Error class	IEC51-1 1.5%
Temperature sensitivity	< +/- 0.1% je 10 °K
Voltage sensitivity	< +/- 0.1% for 10% change in operating voltage
Reaction time	< 300 ms
Measuring suppression	Approx. 2 s after turning on the operating voltage
Vibration resistance	IEC60068-T2-6 15g increased strain, characteristic 2 (10 ... 100 Hz)
Shock resistance (impact)	DIN IEC60068-T2-27 300 m/s <sup>2</sup> with 18 ms dwell time
Climatic test	IEC60068-T2-30
Operating temperature	-20 °C ... +70 °C
Shelf temperature	-45 °C ... +85 °C
Humidity	RH 96% maximum
ESD	IEC61000-4-2 +/- 8 kV
Electromagnetic field	IEC61000-4-3 10 V/m f=10 kHz ... 2000 MHz, 80% AM @ 1 kHz 10 V/m f=900 +/- 5 MHz, 50% AM @ 200 Hz 10 V/m f=1800 MHz +/- 5 MHz, 50% AM @ 200 Hz
Burst	IEC61000-4-4 +/- 2 kV supply +/- 1 kV sensor
Surge	IEC61000-4-5 sym. +/- 1 kV ( $R=2 \Omega$ ) asym. +/- 2 kV ( $R=2 \Omega$ )
HF-susceptibility	IEC61000-4-6 3 V <sub>pp</sub> 80% AM @ 1 kHz f=0.01 ... 100 MHz
LF-susceptibility	IEC60553 3 V <sub>pp</sub> 0.05 ... 10 kHz
Interference field intensity	Basis CISPR 16-1, 16-2 reduced characteristic
Connection	DIN46244 flat connector, gold-plated A6.3 x 0.8
Protection class	DIN EN60529 Body IP20, terminals IP00
Mounting	Snap-fit on top-hat channel or G-channel
Installed position	Any
Body material	Thermoplastic polyester, green, fire protection class V0
Weight	55 g
Standard supply	CE requirements complied with, DIN EN 61000-6-2, DIN EN 61000-6-4, DIN EN 50155, approved by GL, LR, ABS, DNV, BV

## Type key / variants

Input range:	2 ... 20 V/AC	6 ... 60 V/AC	9 ... 90 V/AC
Make-and-break in closed circuit	RW53	RW54	RW55
Make-and-break in open circuit	RW53-A	RW54-A	RW55-A
NOC in open circuit with test function and self-holding function	RW53-S	RW54-S	RW55-S
NOC in open circuit with test function	RW53-A2	RW54-A2	RW55-A2

### Device codes

<b>R</b>	Limit-value switch
<b>W</b>	Input signal
<b>5</b>	Type series
<b>3</b>	Input range
<b>4</b>	Input range
<b>5</b>	Input range
<b>A</b>	Variante
<b>A2</b>	Variante
<b>S</b>	Variante

R W 5 3 - A (RW53-A)

## Other Data

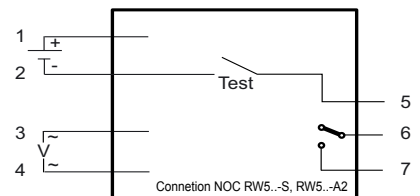
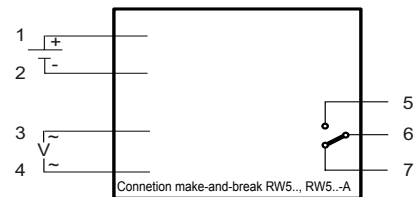
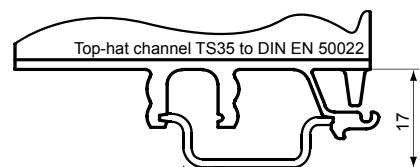
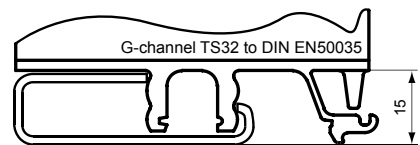
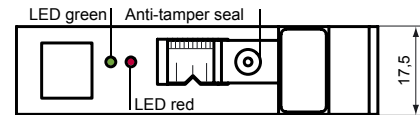
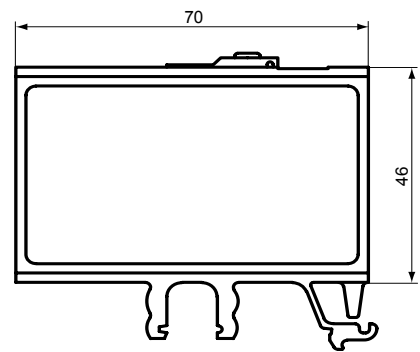

### Relais position and LED code

RW5...	8/7 RW5...-A	5/6 RW5...-A	6/7 RW5...	5/6 RW5...-A	LED grün	LED rot
U < switch point	x	-	-	x	x	-
U > switch point	-	x	x	-	x	x

RW5...-S	8/7 RW5...-S	LED grün	LED rot
U < switch point	-	x	-
U > switch point	x	x	x

x = contact closed / LED lighting

- = contact open / LED out

o = LED flashing



NORIS Automation GmbH  
Muggenhofer Strasse 95

D - 90429 Nürnberg  
Germany  
Tel.: +49 (0)9 11/32 01-0  
Fax: +49 (0)9 11/32 01-150  
info@noris-automation.com  
www.noris-automation.com