

# Measuring transducer for temperature, input Pt100/Pt1000 with two-wire-circuit



VP5..., VPT5..

Measuring Transducers

- Straightforward application
- Suitable for severe operating conditions
- Compact construction
- Galvanic isolation between sensor input and output signal to the operating voltage
- Provision made for fine adjustment of measuring range
- Anti-tamper seal for the fine adjustment
- Meet high EMC-requirements
- **CE** requirements
- Short-circuit-proof output selectable from 0 ... 10 V/DC, 2 ... 10 V/DC, 0 ... 20 mA, 4 ... 20 mA
- Short-circuit monitoring of input signal
- Broken-wire monitoring of input signal
- Operating characteristics displayed by integrated LED
- Flame-inhibiting and self-extinguishing body
- Suitable temperature sensors are available (NORIS-type TP.1, TP.2, TP.3)

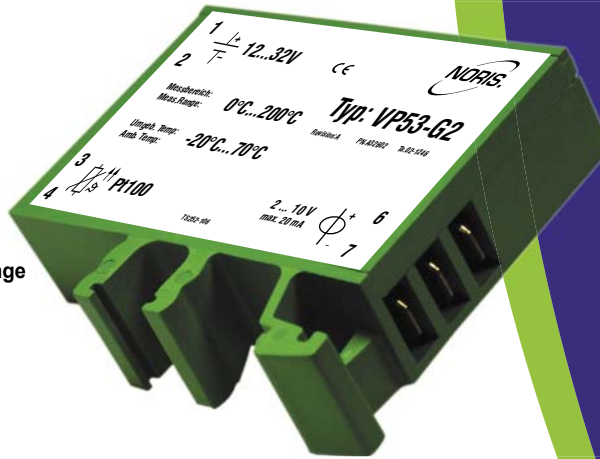

Image VP53-G2



Germanischer Lloyd

## Measuring transducers of series 5

Measuring transducers of the Series 5 are designed to convert electric input values into standardised output signals.

Principle of operation: The transducer signal measured at the converter input is converted into a standardised output signal that is proportional to the input and lends itself to further customised processing, for instance, in a machine controller.

## General notes on Type VP5..., VPT5..

### Description VP5..., VPT5..

The measuring transducers VP5.. and VPT5.. are designed to evaluate the temperature with platinum Pt100 RTD (VP5..) or Pt1000 RTD (VPT5..) according to EN60751 Class B in two-wire circuit. A platinum resistor has a positive temperature coefficient which means that the resistance increases as the temperature rises.

Access is provided to a trimming potentiometer to permit a line compensation to be applied for Pt100 RTD measuring transducers. Pt1000 RTDs do not require such compensation because, in principle, line resistance can be neglected. For better adaption to the required measuring task four measuring ranges are prepared: -30 ... +120 °C, 0 ... 120 °C, 0 ... 150 °C, 0 ... 200 °C.

### Electric isolation

Sensor input and output signals are electrically isolated from the operating voltage. Multiple operation of amplifiers and evaluation devices is therefore possible at the same operating voltage. The sensor only supplies one amplifier device.

### Output signal

The output signal generated is a standardized voltage of 0 ... 10 V/DC or 2 ... 10 V/DC, respectively, a standardized current of 0 ... 20 mA or 4 ... 40 mA. The output signal follows the input signal proportionally.

The output signal can be used to supply additional devices, such as indicating instruments and limit-value switches. Point to be noted: the maximum driver capability of the output.

### Monitoring for integrity and short circuit

The devices are designed with sensor monitored for discontinuity and short circuit. In the event of any fault, the output signal setting is 22 mA or, respectively, 11.5 V.

### Operating status display by LED

The green LED will be lit when the operating voltage is applied and the device is working normally and also when a broken wire occurs, it will be flashing in case of short circuit. In addition triggers a broken wire und a short circuit the fault signal.

## Technical Data

Series VP5.., VPT5..	
Operating voltage	$U_o=12 \dots 32$ V/DC, $U_R=24$ V/DC
Ripple	$< 20\%$ $U_o$
Reverse voltage protection	Integrated
Overvoltage	2.5 times $U_R$ up to 2 ms
Voltage drops	100% up to 10 ms
Power consumption	Approx. 50 mA (24 V/DC)
Galvanic isolation	Between sensor input and output signal to the operating voltage
Input signal	Pt100/Pt1000 RTD two-wire circuit according to EN60751 Class B
Measuring current	VP5.. approx. 2 mA, VPT5.. approx. 1,5 mA
Output VPx5..-G.	0 ... 10 V/DC (VPx5..-G1), 2 ... 10 V/DC (VPx5..-G2), short-circuit-proof, load current 20 mA max.
Output VPx5..-I.	0 ... 20 mA (VPx5..-I1), 4 ... 20 mA (VPx5..-I2), load resistance 500 $\Omega$ max.
Noise voltage	Approx. 20 mV
Linearity error	$< \pm 0.3\%$
Error class	IEC51-1 1.5%
Temperature sensitivity	$< \pm 0.1\%$ per 10 °K
Voltage sensitivity	$< \pm 0.1\%$ for 10% change in operating voltage
Load sensitivity	$< \pm 0.1\%$ for 50% change in load current
Vibration resistance	IEC60068-T2-6 15g increased strain, characteristic 2 (10 ... 100 Hz)
Shock resistance (impact)	DIN IEC60068-T2-27 300 m/s <sup>2</sup> with 18 ms dwell time
Climatic test	IEC60068-T2-30
Operating temperature	-20 °C ... +70 °C
Shelf temperature	-45 °C ... +85 °C
Humidity	RH 96% maximum
ESD	IEC61000-4-2 $\pm 8$ kV
Electromagnetic field	IEC61000-4-3 10 V/m f=10 kHz ... 2000 MHz, 80% AM @ 1 kHz 10 V/m f=900 $\pm$ 5 MHz, 50% AM @ 200 Hz 10 V/m f=1800 MHz $\pm$ 5 MHz, 50% AM @ 200 Hz
Burst	IEC61000-4-4 $\pm 2$ kV supply $\pm 1$ kV sensor
Surge	IEC61000-4-5 sym. $\pm 1$ kV ( $R_f=2 \Omega$ ) asym. $\pm 2$ kV ( $R_f=2 \Omega$ )
HF-susceptibility	IEC61000-4-6 3 $V_{pp}$ , 80% AM @ 1 kHz f=0.01 ... 100 MHz
LF-susceptibility	IEC60553 3 $V_{pp}$ , 0.05 ... 10 kHz
Interference field intensity	Basis CISPR 16-1, 16-2 reduced characteristic
Connection	DIN46244 flat connector, gold-plated A6.3 x 0.8
Protection class	DIN EN60529 Body IP20, terminals IP00
Mounting	Snap-fit on top-hat channel or G-channel
Installed position	Any
Body material	Thermoplastic polyester, green, fire protection class V0
Weight	55 g
Standard supply	CE requirements complied with, DIN EN 61000-6-2, DIN EN 61000-6-4, DIN EN 50155, approved by GL, LR, ABS, DNV, BV

## Other Data

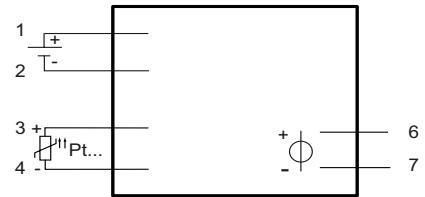
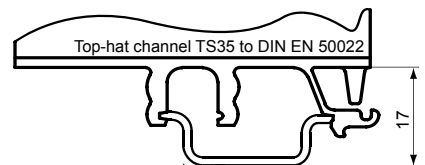
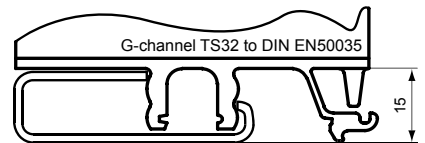
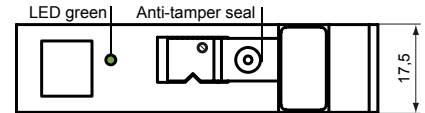
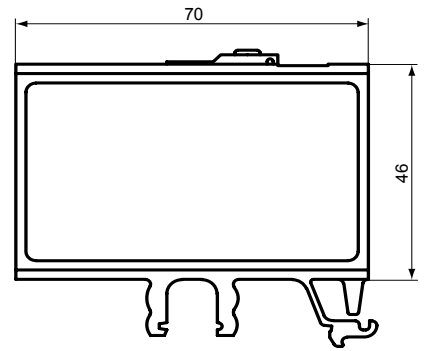

## Type key / variants

Input range:	-30 ... 120 °C		0 ... 120 °C		0 ... 150 °C		0 ... 200 °C	
	Pt100	Pt1000	Pt100	Pt1000	Pt100	Pt1000	Pt100	Pt1000
Output: 0 ... 10 V/DC	VP511-G1	VPT511-G1	VP51-G1	VPT51-G1	VP52-G1	VPT52-G1	VP53-G1	VPT53-G1
Output: 2 ... 10 V/DC	VP511-G2	VPT511-G2	VP51-G2	VPT51-G2	VP52-G2	VPT52-G2	VP53-G2	VPT53-G2
Output: 0 ... 20 mA	VP511-I1	VPT511-I1	VP51-I1	VPT51-I1	VP52-I1	VPT52-I1	VP53-I1	VPT53-I1
Output: 4 ... 20 mA	VP511-I2	VPT511-I2	VP51-I2	VPT51-I2	VP52-I2	VPT52-I2	VP53-I2	VPT53-I2

### Device codes

V	Measuring transducer
Input signal	
P	Pt100 (at 0°C 100 $\Omega$ )
PT	Pt100 (at 0°C 1000 $\Omega$ )
Type series	
5	Type 5
Input range	
11	-30 ... 120 °C
1	0 ... 120 °C
2	0 ... 150 °C
3	0 ... 200 °C
Variants	
G1	Output 0 ... 10 V/DC, short-circuit-proof
G2	Output 2 ... 10 V/DC, short-circuit-proof
I1	Output 0 ... 20 mA
I2	Output 4 ... 20 mA

V P 5 1 -I2 (VP51-I2)

### LED code

x= LED lighting  
- = LED out  
o= LED flashing

	LED green
Operating	x
Short-circuit	O (and failure signal)
Wire-break	X (and failure signal)



NORIS Automation GmbH  
Muggenhofer Strasse 95

D - 90429 Nürnberg  
Germany  
Tel.: +49 (9 11)32 01-0  
Fax: +49 (9 11)32 01-150  
info@noris-automation.com  
www.noris-automation.com